

MC10EP016, MC100EP016

3.3V / 5V ECL 8-Bit Synchronous Binary Up Counter

The MC10/100EP016 is a high-speed synchronous, presettable, cascadeable 8-bit binary counter. Architecture and operation are the same as the MC10E016 in the ECLinPST™ family.

The counter features internal feedback to \overline{TC} gated by the TCLD (Terminal Count Load) pin. When TCLD is LOW (or left open, in which case it is pulled LOW by the internal pulldowns), the \overline{TC} feedback is disabled, and counting proceeds continuously, with \overline{TC} going LOW to indicate an all-one state. When TCLD is HIGH, the TC feedback causes the counter to automatically reload upon TC = LOW, thus functioning as a programmable counter. The Qn outputs do not need to be terminated for the count function to operate properly. To minimize noise and power, unused Q outputs should be left unterminated.

CO \overline{UT} and \overline{COUT} provide differential outputs from a single, non-cascaded counter or divider application. CO \overline{UT} and \overline{COUT} should not be used in cascade configuration. Only \overline{TC} should be used for a counter or divider cascade chain output.

A differential clock input has also been added to improve performance.

The 100 Series contains temperature compensation.

- 500 ps Typical Propagation Delay
- PECL Mode Operating Range: $V_{CC} = 3.0\text{ V}$ to 5.5 V with $V_{EE} = 0\text{ V}$
- NECL Mode Operating Range: $V_{CC} = 0\text{ V}$ with $V_{EE} = -3.0\text{ V}$ to -5.5 V
- Open Input Default State
- Safety Clamp on Inputs
- Internal \overline{TC} Feedback (Gated)
- Addition of CO \overline{UT} and \overline{COUT}
- 8-Bit
- Differential Clock Input
- V_{BB} Output
- Fully Synchronous Counting and \overline{TC} Generation
- Asynchronous Master Reset



ON Semiconductor®

<http://onsemi.com>

MARKING DIAGRAM*



LQFP-32
FA SUFFIX
CASE 873A

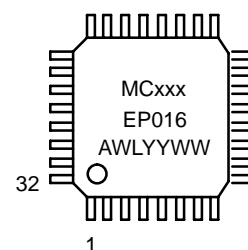

xxx = 10 OR 100
A = Assembly Location
WL = Wafer Lot
YY = Year
WW = Work Week

*For additional information, see Application Note AND8002/D

ORDERING INFORMATION

Device	Package	Shipping
MC10EP016FA	LQFP-32	250 Units/Tray
MC10EP016FAR2	LQFP-32	2000 Tape & Reel
MC100EP016FA	LQFP-32	250 Units/Tray
MC100EP016FAR2	LQFP-32	2000 Tape & Reel

MC10EP016, MC100EP016

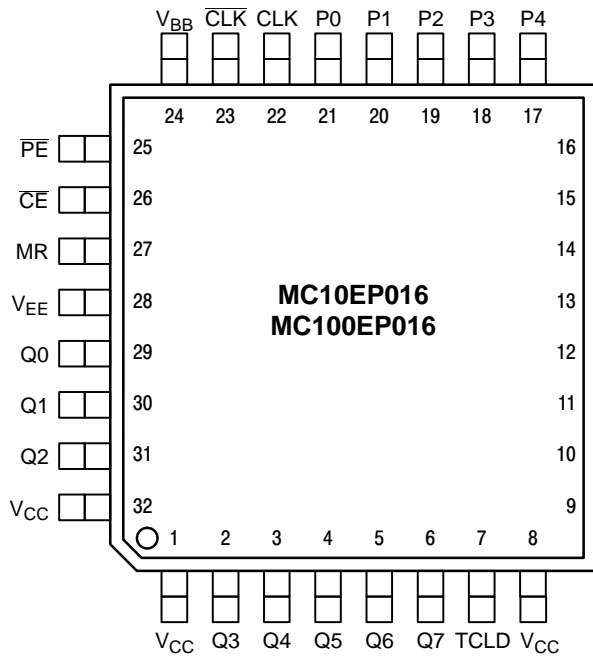

PIN DESCRIPTION

PIN	FUNCTION
P0–P7*	ECL Parallel Data (Preset) Inputs
Q0–Q7	ECL Data Outputs
\overline{CE}^*	ECL Count Enable Control Input
\overline{PE}^*	ECL Parallel Load Enable Control Input
MR*	ECL Master Reset
CLK*, \overline{CLK}^*	ECL Differential Clock
\overline{TC}	ECL Terminal Count Output
TCLD*	ECL TC–Load Control Input
COUT, \overline{COUT}	ECL Differential Output
V _{CC}	Positive Supply
V _{EE}	Negative Supply
V _{BB}	Reference Voltage Output

* Pins will default LOW when left open.

Warning: All V_{CC} and V_{EE} pins must be externally connected to Power Supply to guarantee proper operation.

Figure 1. 32-Lead LQFP Pinout (Top View)

FUNCTION TABLES

\overline{CE}	\overline{PE}	TCLD	MR	CLK	FUNCTION
X	L	X	L	Z	Load Parallel (Pn to Qn)
L	H	L	L	Z	Continuous Count
L	H	H	L	Z	Count; Load Parallel on \overline{TC} = LOW
H	H	X	L	Z	Hold
X	X	X	L	ZZ	Masters Respond, Slaves Hold
X	X	X	H	X	Reset (Qn := LOW, \overline{TC} := HIGH)

ZZ = Clock Pulse (High-to-Low)
Z = Clock Pulse (Low-to-High)

FUNCTION TABLE

Function	\overline{PE}	\overline{CE}	MR	TCLD	CLK	P7–P4	P3	P2	P1	P0	Q7–Q4	Q3	Q2	Q1	Q0	\overline{TC}	\overline{COUT}	COUT
Load Count	L	X	L	X	Z	H	H	H	L	L	H	H	H	L	L	H	H	L
	H	L	L	L	Z	X	X	X	X	X	H	H	H	L	L	H	H	L
	H	L	L	L	Z	X	X	X	X	X	H	H	H	H	H	L	H	L
	H	L	L	L	Z	X	X	X	X	X	L	L	L	L	L	H	H	L
Load Hold	L	X	L	X	Z	H	H	H	L	L	H	H	H	L	L	H	H	L
	H	H	L	X	Z	X	X	X	X	X	H	H	H	L	L	H	H	L
	H	H	L	X	Z	X	X	X	X	X	H	H	H	L	L	H	H	L
Load on Terminal Count	H	L	L	H	Z	H	L	H	H	L	H	H	H	L	H	H	H	L
	H	L	L	H	Z	H	L	H	H	L	H	H	H	H	L	H	H	L
	H	L	L	H	Z	H	L	H	H	L	H	L	H	H	L	H	H	L
	H	L	L	H	Z	H	L	H	H	L	H	L	H	H	H	H	H	L
	H	L	L	H	Z	H	L	H	H	L	H	H	L	L	L	H	H	L
Reset	X	X	H	X	X	X	X	X	X	X	L	L	L	L	L	H	H	L

MC10EP016, MC100EP016

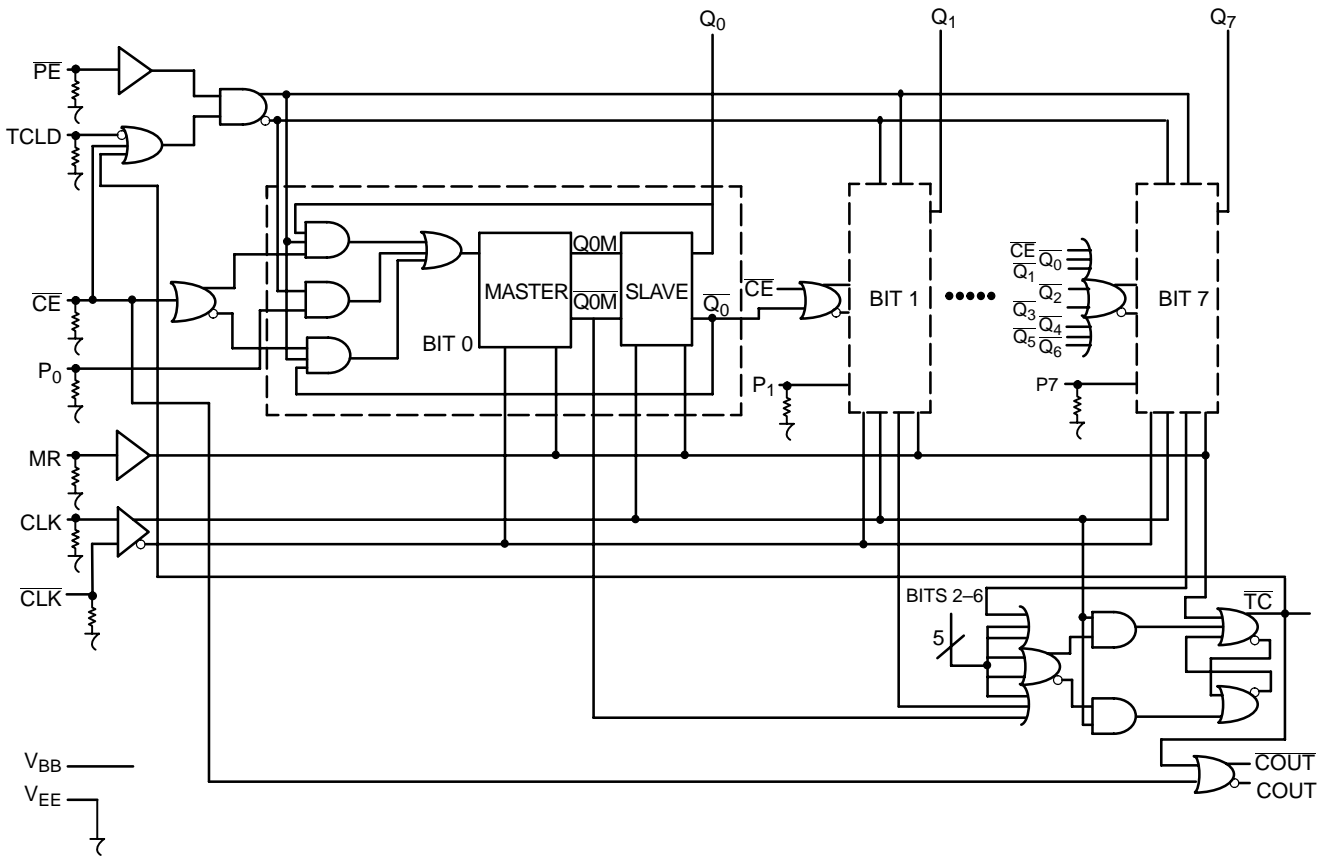

Note that this diagram is provided for understanding of logic operation only. It should not be used for propagation delays as many gate functions are achieved internally without incurring a full gate delay.

Figure 2. 8-BIT Binary Counter Logic Diagram

ATTRIBUTES

Characteristics		Value
Internal Input Pulldown Resistor		75 kΩ
Internal Input Pullup Resistor		N/A
ESD Protection	Human Body Model	> 2 kV
	Machine Model	> 100 V
	Charged Device Model	> 2 kV
Moisture Sensitivity (Note 1)		Level 2
Flammability Rating	Oxygen Index: 28 to 34	UL 94 V-0 @ 0.125 in
Transistor Count		897 Devices
Meets or exceeds JEDEC Spec EIA/JESD78 IC Latchup Test		

1. For additional information, see Application Note AND8003/D.

MC10EP016, MC100EP016

MAXIMUM RATINGS (Note 2)

Symbol	Parameter	Condition 1	Condition 2	Rating	Units
V _{CC}	PECL Mode Power Supply	V _{EE} = 0 V		6	V
V _{EE}	NECL Mode Power Supply	V _{CC} = 0 V		-6	V
V _I	PECL Mode Input Voltage NECL Mode Input Voltage	V _{EE} = 0 V V _{CC} = 0 V	V _I ≤ V _{CC} V _I ≥ V _{EE}	6 -6	V V
I _{out}	Output Current	Continuous Surge		50 100	mA mA
I _{BB}	V _{BB} Sink/Source			± 0.5	mA
T _A	Operating Temperature Range			-40 to +85	°C
T _{stg}	Storage Temperature Range			-65 to +150	°C
θ _{JA}	Thermal Resistance (Junction-to-Ambient)	0 LFPM 500 LFPM	32 LQFP 32 LQFP	80 55	°C/W °C/W
θ _{JC}	Thermal Resistance (Junction-to-Case)	std bd	32 LQFP	12 to 17	°C/W
T _{sol}	Wave Solder	<2 to 3 sec @ 248°C		265	°C

2. Maximum Ratings are those values beyond which device damage may occur.

10EP DC CHARACTERISTICS, PECL V_{CC} = 3.3 V, V_{EE} = 0 V (Note 3)

Symbol	Characteristic	-40°C			25°C			85°C			Unit
		Min	Typ	Max	Min	Typ	Max	Min	Typ	Max	
I _{EE}	Power Supply Current	120	160	200	120	160	200	120	160	200	mA
V _{OH}	Output HIGH Voltage (Note 4)	2165	2290	2415	2230	2355	2480	2290	2415	2540	mV
V _{OL}	Output LOW Voltage (Note 4)	1365	1490	1615	1430	1555	1680	1490	1615	1740	mV
V _{IH}	Input HIGH Voltage (Single-Ended)	2090		2415	2155		2480	2215		2540	mV
V _{IL}	Input LOW Voltage (Single-Ended)	1365		1690	1460		1755	1490		1815	mV
V _{BB}	Output Voltage Reference	1790	1890	1990	1855	1955	2055	1915	2015	2115	mV
V _{IHCMR}	Input HIGH Voltage Common Mode Range (Differential) (Note 5)	2.0		3.3	2.0		3.3	2.0		3.3	V
I _{IH}	Input HIGH Current			150			150			150	μA
I _{IL}	Input LOW Current	0.5			0.5			0.5			μA

NOTE: EP circuits are designed to meet the DC specifications shown in the above table after thermal equilibrium has been established. The circuit is in a test socket or mounted on a printed circuit board and transverse airflow greater than 500 lfm is maintained.

3. Input and output parameters vary 1:1 with V_{CC}. V_{EE} can vary +0.3 V to -2.2 V.

4. All loading with 50 Ω to V_{CC}-2.0 volts.

5. V_{IHCMR} min varies 1:1 with V_{EE}. V_{IHCMR} max varies 1:1 with V_{CC}. The V_{IHCMR} range is referenced to the most positive side of the differential input signal.

10EP DC CHARACTERISTICS, PECL V_{CC} = 5.0 V, V_{EE} = 0 V (Note 6)

Symbol	Characteristic	-40°C			25°C			85°C			Unit
		Min	Typ	Max	Min	Typ	Max	Min	Typ	Max	
I _{EE}	Power Supply Current (Note 7)	120	160	200	120	160	200	120	160	200	mA
V _{OH}	Output HIGH Voltage (Note 8)	3865	3990	4115	3930	4055	4180	3990	4115	4240	mV
V _{OL}	Output LOW Voltage (Note 8)	3065	3190	3315	3130	3255	3380	3190	3315	3440	mV
V _{IH}	Input HIGH Voltage (Single-Ended)	3790		4115	3855		4180	3915		4240	mV
V _{IL}	Input LOW Voltage (Single-Ended)	3065		3390	3130		3455	3190		3515	mV
V _{BB}	Output Voltage Reference	3490	3590	3690	3555	3655	3755	3615	3715	3815	mV
V _{IHCMR}	Input HIGH Voltage Common Mode Range (Differential) (Note 9)	2.0		5.0	2.0		5.0	2.0		5.0	V
I _{IH}	Input HIGH Current			150			150			150	μA
I _{IL}	Input LOW Current	0.5			0.5			0.5			μA

NOTE: EP circuits are designed to meet the DC specifications shown in the above table after thermal equilibrium has been established. The circuit is in a test socket or mounted on a printed circuit board and transverse airflow greater than 500 lfm is maintained.

6. Input and output parameters vary 1:1 with V_{CC}. V_{EE} can vary +2.0 V to -0.5 V.

7. Required 500 lfm air flow when using +5 V power supply. For (V_{CC} - V_{EE}) > 3.3 V, 5 Ω to 10 Ω in line with V_{EE} required for maximum thermal protection at elevated temperatures. Recommend V_{CC}-V_{EE} operation at ≤ 3.3 V.

8. All loading with 50 Ω to V_{CC}-2.0 volts.

9. V_{IHCMR} min varies 1:1 with V_{EE}. V_{IHCMR} max varies 1:1 with V_{CC}. The V_{IHCMR} range is referenced to the most positive side of the differential input signal.

MC10EP016, MC100EP016

10EP DC CHARACTERISTICS, NECL $V_{CC} = 0\text{ V}$, $V_{EE} = -5.5\text{ V}$ to -3.0 V (Note 10)

Symbol	Characteristic	-40°C			25°C			85°C			Unit
		Min	Typ	Max	Min	Typ	Max	Min	Typ	Max	
I_{EE}	Power Supply Current (Note 11)	120	160	200	120	160	200	120	160	200	mA
V_{OH}	Output HIGH Voltage (Note 12)	-1135	-1010	-885	-1070	-945	-820	-1010	-885	-760	mV
V_{OL}	Output LOW Voltage (Note 12)	-1935	-1810	-1685	-1870	-1745	-1620	-1810	-1685	-1560	mV
V_{IH}	Input HIGH Voltage (Single-Ended)	-1210		-885	-1145		-820	-1085		-760	mV
V_{IL}	Input LOW Voltage (Single-Ended)	-1935		-1610	-1870		-1545	-1810		-1485	mV
V_{BB}	Output Voltage Reference	-1510	-1410	-1310	-1445	-1345	-1245	-1385	-1285	-1185	mV
V_{IHCMR}	Input HIGH Voltage Common Mode Range (Differential) (Note 13)	$V_{EE}+2.0$		0.0	$V_{EE}+2.0$		0.0	$V_{EE}+2.0$		0.0	V
I_{IH}	Input HIGH Current			150			150			150	μA
I_{IL}	Input LOW Current	0.5			0.5			0.5			μA

NOTE: EP circuits are designed to meet the DC specifications shown in the above table after thermal equilibrium has been established. The circuit is in a test socket or mounted on a printed circuit board and transverse airflow greater than 500 lpm is maintained.

10. Input and output parameters vary 1:1 with V_{CC} .

11. Required 500 lpm air flow when using -5 V power supply. For $(V_{CC} - V_{EE}) > 3.3\text{ V}$, $5\ \Omega$ to $10\ \Omega$ in line with V_{EE} required for maximum thermal protection at elevated temperatures. Recommend $V_{CC}-V_{EE}$ operation at $\leq 3.3\text{ V}$.

12. All loading with $50\ \Omega$ to $V_{CC}-2.0$ volts.

13. V_{IHCMR} min varies 1:1 with V_{EE} . V_{IHCMR} max varies 1:1 with V_{CC} . The V_{IHCMR} range is referenced to the most positive side of the differential input signal.

100EP DC CHARACTERISTICS, PECL $V_{CC} = 3.3\text{ V}$, $V_{EE} = 0\text{ V}$ (Note 14)

Symbol	Characteristic	-40°C			25°C			85°C			Unit
		Min	Typ	Max	Min	Typ	Max	Min	Typ	Max	
I_{EE}	Power Supply Current	120	160	200	120	160	200	120	160	200	mA
V_{OH}	Output HIGH Voltage (Note 15)	2155	2280	2405	2155	2280	2405	2155	2280	2405	mV
V_{OL}	Output LOW Voltage (Note 15)	1355	1480	1605	1355	1480	1605	1355	1480	1605	mV
V_{IH}	Input HIGH Voltage (Single-Ended)	2075		2420	2075		2420	2075		2420	mV
V_{IL}	Input LOW Voltage (Single-Ended)	1355		1675	1355		1675	1355		1675	mV
V_{BB}	Output Voltage Reference	1775	1875	1975	1775	1875	1975	1775	1875	1975	mV
V_{IHCMR}	Input HIGH Voltage Common Mode Range (Differential) (Note 16)	2.0		3.3	2.0		3.3	2.0		3.3	V
I_{IH}	Input HIGH Current			150			150			150	μA
I_{IL}	Input LOW Current	0.5			0.5			0.5			μA

NOTE: EP circuits are designed to meet the DC specifications shown in the above table after thermal equilibrium has been established. The circuit is in a test socket or mounted on a printed circuit board and transverse airflow greater than 500 lpm is maintained.

14. Input and output parameters vary 1:1 with V_{CC} . V_{EE} can vary +0.3 V to -2.2 V.

15. All loading with $50\ \Omega$ to $V_{CC}-2.0$ volts.

16. V_{IHCMR} min varies 1:1 with V_{EE} . V_{IHCMR} max varies 1:1 with V_{CC} . The V_{IHCMR} range is referenced to the most positive side of the differential input signal.

100EP DC CHARACTERISTICS, PECL $V_{CC} = 5.0\text{ V}$, $V_{EE} = 0\text{ V}$ (Note 17)

Symbol	Characteristic	-40°C			25°C			85°C			Unit
		Min	Typ	Max	Min	Typ	Max	Min	Typ	Max	
I_{EE}	Power Supply Current (Note 18)	120	160	200	120	160	200	120	160	200	mA
V_{OH}	Output HIGH Voltage (Note 19)	3855	3980	4105	3855	3980	4105	3855	3980	4105	mV
V_{OL}	Output LOW Voltage (Note 19)	3055	3180	3305	3055	3180	3305	3055	3180	3305	mV
V_{IH}	Input HIGH Voltage (Single-Ended)	3775		4120	3775		4120	3775		4120	mV
V_{IL}	Input LOW Voltage (Single-Ended)	3055		3375	3055		3375	3055		3375	mV
V_{BB}	Output Voltage Reference	3475	3575	3675	3475	3575	3675	3475	3575	3675	mV
V_{IHCMR}	Input HIGH Voltage Common Mode Range (Differential) (Note 20)	2.0		5.0	2.0		5.0	2.0		5.0	V
I_{IH}	Input HIGH Current			150			150			150	μA
I_{IL}	Input LOW Current	0.5			0.5			0.5			μA

NOTE: EP circuits are designed to meet the DC specifications shown in the above table after thermal equilibrium has been established. The circuit is in a test socket or mounted on a printed circuit board and transverse airflow greater than 500 lpm is maintained.

17. Input and output parameters vary 1:1 with V_{CC} . V_{EE} can vary +2.0 V to -0.5 V.

18. Required 500 lpm air flow when using +5 V power supply. For $(V_{CC} - V_{EE}) > 3.3\text{ V}$, $5\ \Omega$ to $10\ \Omega$ in line with V_{EE} required for maximum thermal protection at elevated temperatures. Recommend $V_{CC}-V_{EE}$ operation at $\leq 3.3\text{ V}$.

19. All loading with $50\ \Omega$ to $V_{CC}-2.0$ volts.

20. V_{IHCMR} min varies 1:1 with V_{EE} . V_{IHCMR} max varies 1:1 with V_{CC} . The V_{IHCMR} range is referenced to the most positive side of the differential input signal.

MC10EP016, MC100EP016

100EP DC CHARACTERISTICS, NECL $V_{CC} = 0\text{ V}$, $V_{EE} = -5.5\text{ V}$ to -3.0 V (Note 21)

Symbol	Characteristic	-40°C			25°C			85°C			Unit
		Min	Typ	Max	Min	Typ	Max	Min	Typ	Max	
I_{EE}	Power Supply Current (Note 22)	120	160	200	120	160	200	120	160	200	mA
V_{OH}	Output HIGH Voltage (Note 23)	-1145	-1020	-895	-1145	-1020	-895	-1145	-1020	-895	mV
V_{OL}	Output LOW Voltage (Note 23)	-1945	-1820	-1695	-1945	-1820	-1695	-1945	-1820	-1695	mV
V_{IH}	Input HIGH Voltage (Single-Ended)	-1225		-880	-1225		-880	-1225		-880	mV
V_{IL}	Input LOW Voltage (Single-Ended)	-1945		-1625	-1945		-1625	-1945		-1625	mV
V_{BB}	Output Voltage Reference	-1525	-1425	-1325	-1525	-1425	-1325	-1525	-1425	-1325	mV
V_{IHCMR}	Input HIGH Voltage Common Mode Range (Differential) (Note 24)	$V_{EE}+2.0$		0.0	$V_{EE}+2.0$		0.0	$V_{EE}+2.0$		0.0	V
I_{IH}	Input HIGH Current			150			150			150	μA
I_{IL}	Input LOW Current	0.5			0.5			0.5			μA

NOTE: EP circuits are designed to meet the DC specifications shown in the above table after thermal equilibrium has been established. The circuit is in a test socket or mounted on a printed circuit board and transverse airflow greater than 500 lfm is maintained.

21. Input and output parameters vary 1:1 with V_{CC} .

22. Required 500 lfm air flow when using -5 V power supply. For $(V_{CC} - V_{EE}) > 3.3\text{ V}$, 5 Ω to 10 Ω in line with V_{EE} required for maximum thermal protection at elevated temperatures. Recommend $V_{CC} - V_{EE}$ operation at $\leq 3.3\text{ V}$.

23. All loading with 50 Ω to $V_{CC} - 2.0\text{ volts}$.

24. V_{IHCMR} min varies 1:1 with V_{EE} , V_{IHCMR} max varies 1:1 with V_{CC} . The V_{IHCMR} range is referenced to the most positive side of the differential input signal.

AC CHARACTERISTICS $V_{EE} = -3.0\text{ V}$ to -5.5 V ; $V_{CC} = 0\text{ V}$ or $V_{CC} = 3.0\text{ V}$ to 5.5 V ; $V_{EE} = 0\text{ V}$ (Note 25)

Symbol	Characteristic	-40°C			25°C			85°C			Unit
		Min	Typ	Max	Min	Typ	Max	Min	Typ	Max	
f_{COUNT}	Maximum Frequency Q, \overline{TC} COUT/COUT		> 1 > 800			> 1 > 800			> 1 > 800		GHz MHz
t_{PLH} t_{PHL}	Propagation Delay (10) CLK to Q (10) MR to Q (10) CLK to \overline{TC} (10) MR to \overline{TC} (10) CLK to COUT (10) MR to COUT (100) CLK to Q (100) MR to Q (100) CLK to \overline{TC} (100) MR to \overline{TC} (100) CLK to COUT (100) MR to COUT	300 300 350 250 400 300 350 400 350 400 400 400 400 400 450	460 400 420 350 470 400 500 550 500 550 500 550 500 550 600	600 500 550 450 650 550 650 700 650 750 700 750 800 800	350 400 400 350 450 400 400 450 400 450 450 450 450 450	500 500 500 450 550 500 550 590 550 590 600 640	650 600 600 550 700 650 700 750 700 750 800 850	400 450 400 400 450 450 480 520 480 520 530 570	560 580 550 510 600 560 630 670 630 670 680 720	700 700 700 600 800 700 780 820 780 820 880 920	ps
t_S	Setup Time Pn \overline{CE} PE TCLD	100 500 500 500	-50 300 300 300		100 500 500 500	-50 300 300 300		100 500 500 500	-50 300 300 300		ps
t_H	Hold Time Pn \overline{CE} PE TCLD	100 500 500 500	-50 300 300 300		100 500 500 500	-50 300 300 300		100 500 500 500	-50 300 300 300		ps
t_{JITTER}	Clock Random Jitter (RMS >1000 Waveforms)		2.6	8.5		2.5	8.0		2.5	8.0	ps
t_{RR}	Reset Recovery Time	200	80		200	80		200	80		ps
t_{PW}	Minimum Pulse Width CLK, MR	550	300		550	300		550	300		ps
t_r t_f	Output Rise/Fall Times 20% - 80%	120	210	320	120	220	320	150	250	450	ps

25. Measured using a 750 mV source, 50% duty cycle clock source. All loading with 50 Ω to $V_{CC} - 2.0\text{ V}$.

Applications Information

Cascading Multiple EP016 Devices

For applications which call for larger than 8-bit counters multiple EP016s can be tied together to achieve very wide bit width counters. The active low terminal count (\overline{TC}) output and count enable input (\overline{CE}) greatly facilitate the cascading of EP016 devices. Two EP016s can be cascaded without the need for external gating, however for counters wider than 16 bits external OR gates are necessary for cascade implementations.

Figure 3 below pictorially illustrates the cascading of 4 EP016s to build a 32-bit high frequency counter. Note the EP01 gates used to OR the terminal count outputs of the lower order EP016s to control the counting operation of the higher order bits. When the terminal count of the preceding device (or devices) goes low (the counter reaches an all 1s state) the more significant EP016 is set in its count mode and will count one binary digit upon the next positive clock transition. In addition, the preceding devices will also count

one bit thus sending their terminal count outputs back to a high state disabling the count operation of the more significant counters and placing them back into hold modes. Therefore, for an EP016 in the chain to count, all of the lower order terminal count outputs must be in the low state. The bit width of the counter can be increased or decreased by simply adding or subtracting EP016 devices from Figure 3 and maintaining the logic pattern illustrated in the same figure.

The maximum frequency of operation for a cascaded counter chain is set by the propagation delay of the \overline{TC} output, the necessary setup time of the \overline{CE} input, and the propagation delay through the OR gate controlling it (for 16-bit counters the limitation is only the \overline{TC} propagation delay and the \overline{CE} setup time). Figure 3 shows EP01 gates used to control the count enable inputs, however, if the frequency of operation is slow enough, a LVECL OR gate can be used. Using the worst case guarantees for these parameters.

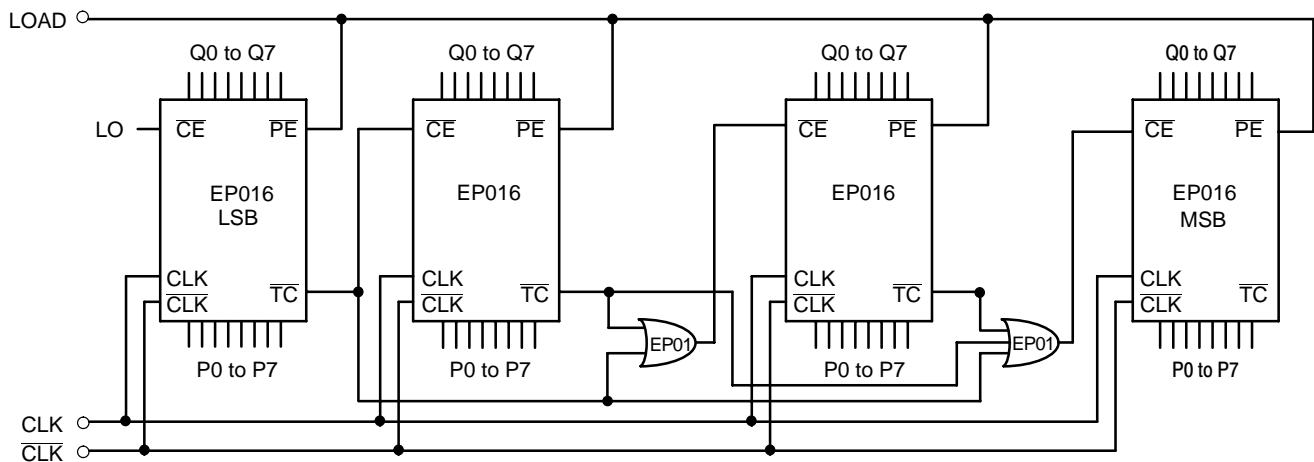

Figure 3. 32-Bit Cascaded EP016 Counter

Note that this assumes the trace delay between the \overline{TC} outputs and the \overline{CE} inputs are negligible. If this is not the case estimates of these delays need to be added to the calculations.

Programmable Divider

The EP016 has been designed with a control pin which makes it ideal for use as an 8-bit programmable divider. The

TCLD pin (load on terminal count) when asserted reloads the data present at the parallel input pin (Pn's) upon reaching terminal count (an all 1s state on the outputs). Because this feedback is built internal to the chip, the programmable division operation will run at very nearly the same frequency as the maximum counting frequency of the device. Figure 4 below illustrates the input conditions necessary for utilizing the EP016 as a programmable divider set up to divide by 113.

Applications Information (continued)

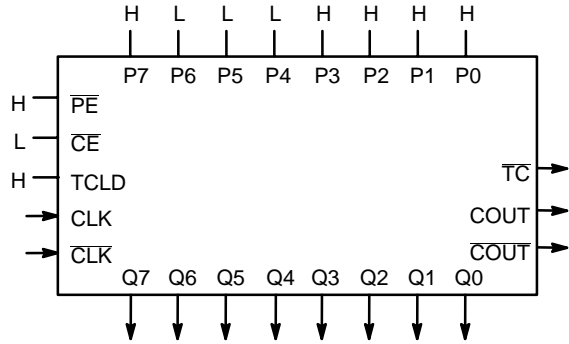

Figure 4. Mod 2 to 256 Programmable Divider

To determine what value to load into the device to accomplish the desired division, the designer simply subtracts the binary equivalent of the desired divide ratio from the binary value for 256. As an example for a divide ratio of 113:

$$Pn's = 256 - 113 = 8F_{16} = 1000\ 1111$$

where:

$$P0 = \text{LSB and } P7 = \text{MSB}$$

Forcing this input condition as per the setup in Figure 4 will result in the waveforms of Figure 5. Note that the TC output is used as the divide output and the pulse duration is equal to a full clock period. For even divide ratios, twice the desired divide ratio can be loaded into the EP016 and the TC output can feed the clock input of a toggle flip flop to create a signal divided as desired with a 50% duty cycle.

Table 1. Preset Values for Various Divide Ratios

Divide Ratio	Preset Data Inputs							
	P7	P6	P5	P4	P3	P2	P1	P0
2	H	H	H	H	H	H	H	L
3	H	H	H	H	H	H	L	H
4	H	H	H	H	H	H	L	L
5	H	H	H	H	H	L	H	H
•	•	•	•	•	•	•	•	•
•	•	•	•	•	•	•	•	•
112	H	L	L	H	L	L	L	L
113	H	L	L	L	H	H	H	H
114	H	L	L	L	H	H	H	L
•	•	•	•	•	•	•	•	•
•	•	•	•	•	•	•	•	•
254	L	L	L	L	L	L	H	L
255	L	L	L	L	L	L	L	H
256	L	L	L	L	L	L	L	L

A single EP016 can be used to divide by any ratio from 2 to 256 inclusive. If divide ratios of greater than 256 are needed multiple EP016s can be cascaded in a manner similar to that already discussed. When EP016s are cascaded to build larger dividers the TCLD pin will no longer provide a means for loading on terminal count. Because one does not want to reload the counters until all of the devices in the chain have reached terminal count, external gating of the TC pins must be used for multiple EP016 divider chains.

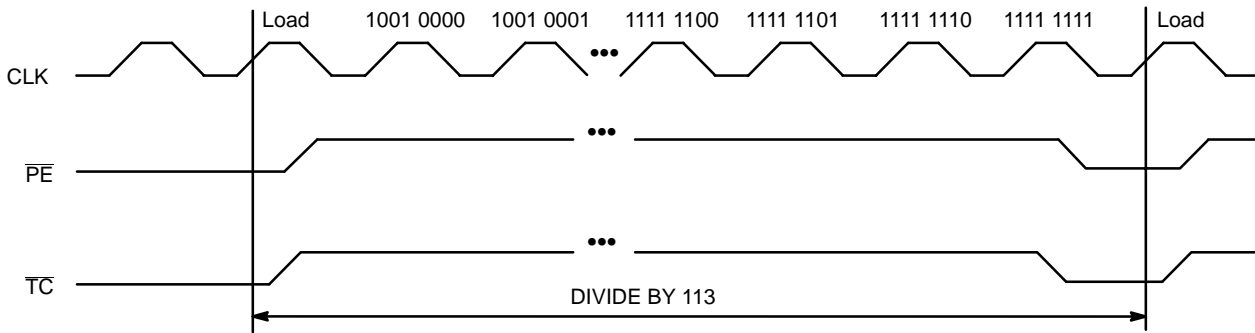

Figure 5. Divide by 113 EP016 Programmable Divider Waveforms

Applications Information (continued)

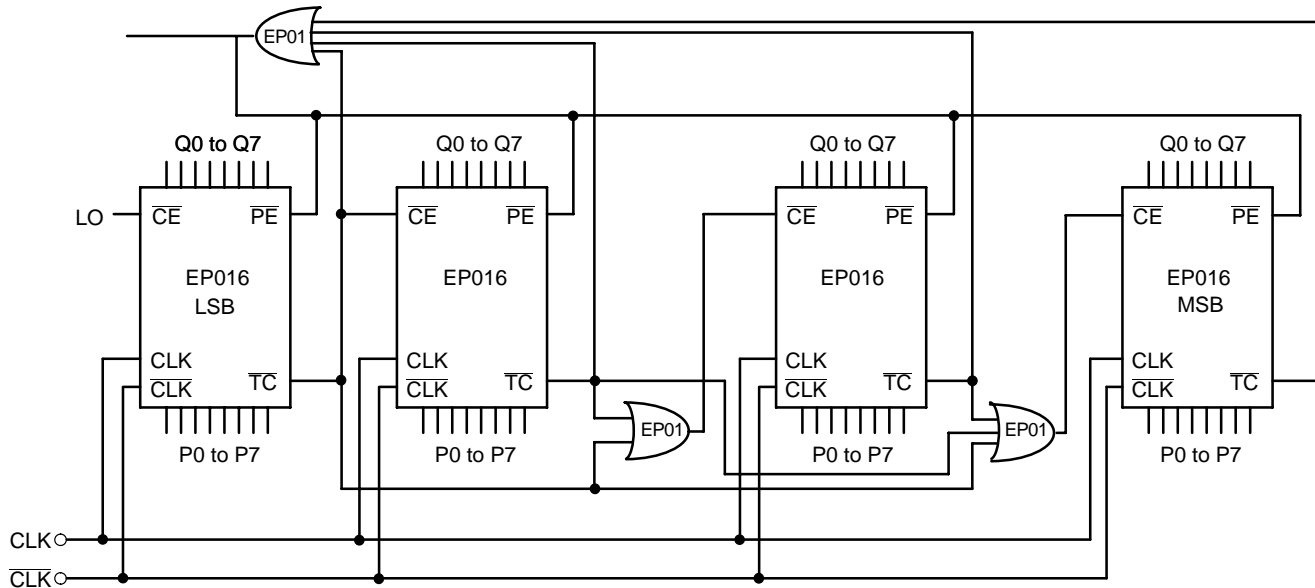

Figure 6. 32-Bit Cascaded EP016 Programmable Divider

Figure 6 shows a typical block diagram of a 32-bit divider chain. Once again to maximize the frequency of operation EP01 OR gates were used. For lower frequency applications a slower OR gate could replace the EP01. Note that for a 16-bit divider the OR function feeding the \overline{PE} (program enable) input CANNOT be replaced by a wire OR tie as the \overline{TC} output of the least significant EP016 must also feed the \overline{CE} input of the most significant EP016. If the two \overline{TC} outputs were OR tied the cascaded count operation would not operate properly. Because in the cascaded form the \overline{PE} feedback is external and requires external gating, the maximum frequency of operation will be significantly less than the same operation in a single device.

Maximizing EP016 Count Frequency

The EP016 device produces 9 fast transitioning single-ended outputs, thus V_{CC} noise can become significant in situations where all of the outputs switch simultaneously in the same direction. This V_{CC} noise can negatively impact the maximum frequency of operation of the device. Since the device does not need to have the Q outputs terminated to count properly, it is recommended that if the outputs are not going to be used in the rest of the system they should be left unterminated. In addition, if only a subset of the Q outputs are used in the system only those outputs should be terminated. Not terminating the unused outputs will not only cut down the V_{CC} noise generated but will also save in total system power dissipation. Following these guidelines will allow designers to either be more aggressive in their designs or provide them with an extra margin to the published data book specifications.

MC10EP016, MC100EP016

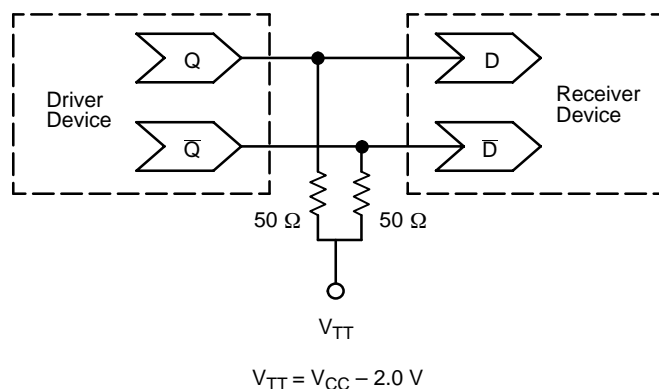

**Figure 7. Typical Termination for Output Driver and Device Evaluation
(See Application Note AND8020 – Termination of ECL Logic Devices.)**

Resource Reference of Application Notes

- AN1404** – ECLinPS Circuit Performance at Non-Standard V_{IH} Levels
- AN1405** – ECL Clock Distribution Techniques
- AN1406** – Designing with PECL (ECL at +5.0 V)
- AN1504** – Metastability and the ECLinPS Family
- AN1568** – Interfacing Between LVDS and ECL
- AN1650** – Using Wire-OR Ties in ECLinPS Designs
- AN1672** – The ECL Translator Guide
- AND8001** – Odd Number Counters Design
- AND8002** – Marking and Date Codes
- AND8009** – ECLinPS Plus Spice I/O Model Kit
- AND8020** – Termination of ECL Logic Devices

For an updated list of Application Notes, please see our website at <http://onsemi.com>.

MC10EP016, MC100EP016

PACKAGE DIMENSIONS

LQFP
FA SUFFIX
32-LEAD PLASTIC PACKAGE
CASE 873A-02
ISSUE A

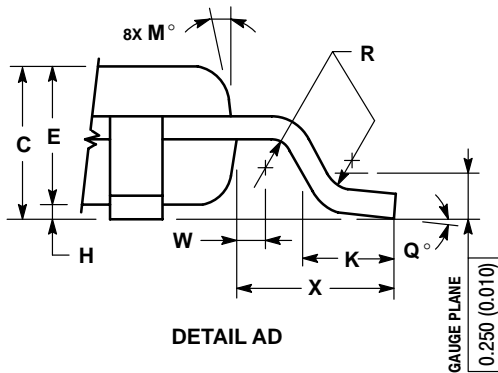
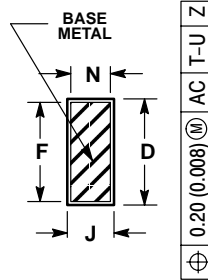
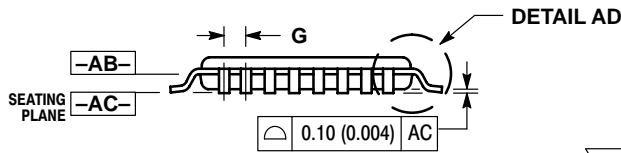
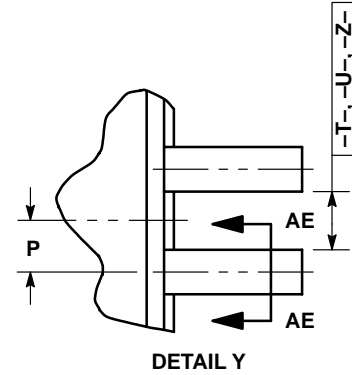
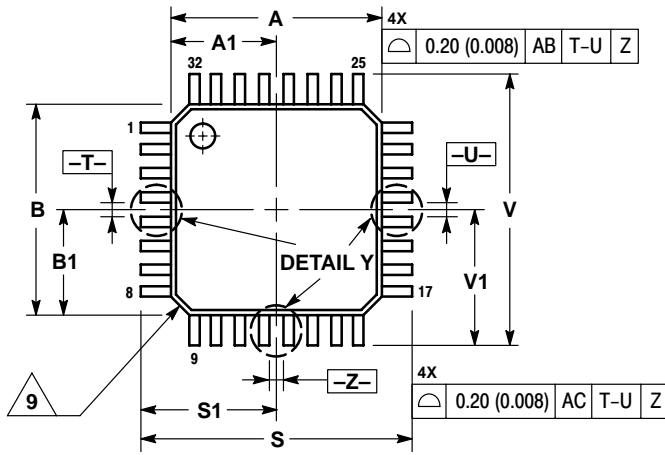

NOTES:

- DIMENSIONING AND TOLERANCING PER ANSI Y14.5M, 1982.
- CONTROLLING DIMENSION: MILLIMETER.
- DATUM PLANE -AB- IS LOCATED AT BOTTOM OF LEAD AND IS COINCIDENT WITH THE LEAD WHERE THE LEAD EXITS THE PLASTIC BODY AT THE BOTTOM OF THE PARTING LINE.
- DATUMS -T-, -U-, AND -Z- TO BE DETERMINED AT DATUM PLANE -AB-.
- DIMENSIONS S AND V TO BE DETERMINED AT SEATING PLANE -AC-.
- DIMENSIONS A AND B DO NOT INCLUDE MOLD PROTRUSION. ALLOWABLE PROTRUSION IS 0.250 (0.010) PER SIDE. DIMENSIONS A AND B DO INCLUDE MOLD MISMATCH AND ARE DETERMINED AT DATUM PLANE -AB-.
- DIMENSION D DOES NOT INCLUDE DAMBAR PROTRUSION. DAMBAR PROTRUSION SHALL NOT CAUSE THE D DIMENSION TO EXCEED 0.520 (0.020).
- MINIMUM SOLDER PLATE THICKNESS SHALL BE 0.0076 (0.0003).
- EXACT SHAPE OF EACH CORNER MAY VARY FROM DEPICTION.

DIM	MILLIMETERS		INCHES	
	MIN	MAX	MIN	MAX
A	7.000 BSC		0.276 BSC	
A1	3.500 BSC		0.138 BSC	
B	7.000 BSC		0.276 BSC	
B1	3.500 BSC		0.138 BSC	
C	1.400	1.600	0.055	0.063
D	0.300	0.450	0.012	0.018
E	1.350	1.450	0.053	0.057
F	0.300	0.400	0.012	0.016
G	0.800 BSC		0.031 BSC	
H	0.050	0.150	0.002	0.006
J	0.090	0.200	0.004	0.008
K	0.500	0.700	0.020	0.028
M	12° REF		12° REF	
N	0.090	0.160	0.004	0.006
P	0.400 BSC		0.016 BSC	
Q	1°	5°	1°	5°
R	0.150	0.250	0.006	0.010
S	9.000 BSC		0.354 BSC	
S1	4.500 BSC		0.177 BSC	
V	9.000 BSC		0.354 BSC	
V1	4.500 BSC		0.177 BSC	
W	0.200 REF		0.008 REF	
X	1.000 REF		0.039 REF	

ECLinPS is a trademark of Semiconductor Components Industries, LLC (SCILLC).

ON Semiconductor and  are registered trademarks of Semiconductor Components Industries, LLC (SCILLC). SCILLC reserves the right to make changes without further notice to any products herein. SCILLC makes no warranty, representation or guarantee regarding the suitability of its products for any particular purpose, nor does SCILLC assume any liability arising out of the application or use of any product or circuit, and specifically disclaims any and all liability, including without limitation special, consequential or incidental damages. "Typical" parameters which may be provided in SCILLC data sheets and/or specifications can and do vary in different applications and actual performance may vary over time. All operating parameters, including "Typicals" must be validated for each customer application by customer's technical experts. SCILLC does not convey any license under its patent rights nor the rights of others. SCILLC products are not designed, intended, or authorized for use as components in systems intended for surgical implant into the body, or other applications intended to support or sustain life, or for any other application in which the failure of the SCILLC product could create a situation where personal injury or death may occur. Should Buyer purchase or use SCILLC products for any such unintended or unauthorized application, Buyer shall indemnify and hold SCILLC and its officers, employees, subsidiaries, affiliates, and distributors harmless against all claims, costs, damages, and expenses, and reasonable attorney fees arising out of, directly or indirectly, any claim of personal injury or death associated with such unintended or unauthorized use, even if such claim alleges that SCILLC was negligent regarding the design or manufacture of the part. SCILLC is an Equal Opportunity/Affirmative Action Employer.

PUBLICATION ORDERING INFORMATION

Literature Fulfillment:

Literature Distribution Center for ON Semiconductor
P.O. Box 5163, Denver, Colorado 80217 USA
Phone: 303-675-2175 or 800-344-3860 Toll Free USA/Canada
Fax: 303-675-2176 or 800-344-3867 Toll Free USA/Canada
Email: ONlit@hibbertco.com

N. American Technical Support: 800-282-9855 Toll Free USA/Canada

JAPAN: ON Semiconductor, Japan Customer Focus Center
2-9-1 Kamimeguro, Meguro-ku, Tokyo, Japan 153-0051
Phone: 81-3-5773-3850
Email: r14525@onsemi.com

ON Semiconductor Website: <http://onsemi.com>

For additional information, please contact your local Sales Representative.